

# A New Electronically Monitored Centrifuge for the Analysis of Plant Growth in Simulated Hypergravity

M. J. A. Nava<sup>\*</sup>, T. Russomano, M. A. dos Santos, L. B. Poehls

Microgravity Centre, PUCRS, Porto Alegre, Brazil

<sup>\*</sup>Corresponding author: [mjanava@gmail.com](mailto:mjanava@gmail.com)

Received May 02, 2015; Revised May 12, 2015; Accepted June 03, 2015

**Abstract** Hypergravity is able to stimulate at a cellular level both the lignin formation and the peroxidase enzyme action in plants. Centrifuges have proven to be one of the most important tools for researchers for simulating such conditions. This paper presents a new design for a centrifuge simulating hypergravity used for plant experiments. It represents a more robust and completely redesigned equipment based on a previous centrifuge project by the MicroG Centre. Distinct experiments using plants have been performed in order to validate the centrifuge. *Eruca Sativa Mill.* samples have undergone growth and germination whilst being submitted to spinning at +7G, both in the new and in a pre-existing centrifuge. The obtained results have been compared to each other and to samples grown under conditions of 1 Gz.

**Keywords:** hypergravity, centrifuge, plants growth

**Cite This Article:** M. J. A. Nava, T. Russomano, M. A. dos Santos, and L. B. Poehls, "A New Electronically Monitored Centrifuge for the Analysis of Plant Growth in Simulated Hypergravity." *American Journal of Medical and Biological Research*, vol. 3, no. 4 (2015): 88-94. doi: 10.12691/ajmbr-3-4-2.

## 1. Introduction

Over the course of time, mankind has strived to improve and increase the supply of food sources, including the development of vegetable matter that is more nutritious, sustainable, and disease and environment resistant. Advances in pesticide research and use have led to greater productivity, whilst progress in biotechnology in the last few decades has seen the introduction of genetically modified species of plant. Nowadays, however, the most important challenge is to create a more sustainable agriculture using the principles of ecology, to avoid potential harm to natural environmental systems.

The *National Aeronautic and Space Administration* (NASA) has concentrated its efforts on a better understanding of how the gravitational force spectrum influences the development of life. To do so, it has conducted tests during space missions (microgravity), as well as earth-based research using small-scale centrifuges (hypergravity) [2]. The increased knowledge achieved by such research has led to mankind considering the application of a natural force as the main principle for vegetable manipulation, in contrast to the use of chemicals or genetic modifications.

Centrifuges are equipment designed to apply a centrifugal force directly on a target object by means of rotation around an axis. Studies concerning the effects provoked by centrifugation on living beings began as early as the 19th century, when very basic centrifuges (little more than gyratory machines used for milling corn) were employed for the treatment of mental-health issues.

Subsequently, the development of larger and more complex centrifuges took place during World War II aimed specifically at military pilot training. Nowadays, human centrifuges are used by space agencies as part of astronaut training programs [6]. In addition, small-scale centrifuges are employed for the separation of chemical mixture phases, whilst ultracentrifuges have been created with engine capacities capable of acceleration up to 500 times the gravitational force, for biotechnology application [4]. More recently, the construction of centrifuges especially designed for vegetable growth research has begun.

NASA's Ames Research Centre (ARC) has conducted terrestrial based studies of simulated hypergravity in order to understand plant reactions (at morphological and cellular level) to the effects of a range of different gravity gradients. These studies complement the research carried out in microgravity (0Gz) at the International Space Station (ISS) regarding the potential for future food growth in space. The ARC uses a specially designed centrifuge for studies with cell cultures and plants, called *Hypergravity Facility for Cell Culture* (HyFaCC). This equipment, based on a human centrifuge model, has a single arm of 2.74 m with an onboard incubator. It is powered by a 20 HP engine that can reach up to a maximum of 12 Gz. The HyFaCC allows long-term research, with the inclusion of a programmable automatic control research protocol. The latest small-scale centrifuges, with a maximum radius of 0.50 m, allow generation of up to +25 Gz at the ARC. Both types of centrifuge have an integrated monitoring system controlling temperature, relative humidity and atmosphere, as well as a system for data collection and filming of the

cell growth to enable a more in-depth understanding of the development of plant species [5].

The Technology Centre (ESTEC) of the European Space Agency (ESA) also has a specific test centrifuge for non-human elements, for studies conducted in partnership with the European Association for Research in Low and High Gravity (ELGRA). This research includes the study of the effects of gravity on the surface treatment of metallic materials; the effect of hypergravity on the behaviour of a liquid droplet when in contact with a flat, solid surface; plants and hypergravity stresses; effect of hypergravity on cells in the growth of pollen tubes [6]. The University of Moscow has been conducting plant research centrifuges for a decade.

More recently, researchers have designed a low cost small-scale centrifuge as an alternative tool for use in laboratory hypergravity simulation tests. The project followed a similar design to an ESA model, and uses small containers (to hold plant samples or small animals) that are secured to three platforms, with these being attached to a central axis.

The main technique for simulating hypergravity is the creation of an artificial condition by means of a resultant force between weight and the centrifugal acceleration. Figure 1 shows this concept.

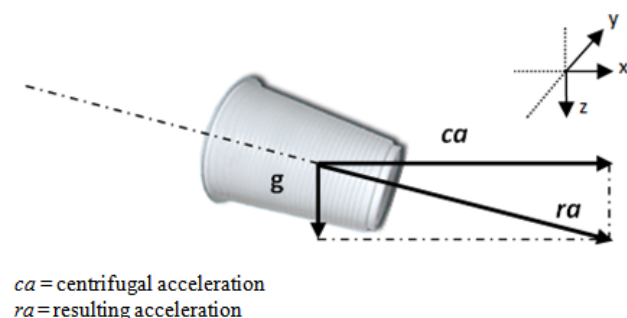

**Figure 1.** Schematic representation of the system accelerations produced by forces acting on the sample container during centrifugation, where  $g$  = acceleration of gravity,  $ca$  = centrifugal acceleration and  $ra$  = resulting acceleration. The detail in the upper right shows an isometric view from the top tray of the centrifuge, indicating the direction and sense of its Cartesian axes in order to facilitate the identification of acceleration application.

In Figure 1, the acceleration of gravity ( $g$ ) is performed by the natural action of gravity present on the Z axis (equivalent to +1Gz and is concentrated in the centre of body mass). The centrifugal acceleration ( $ca$ ) created by rotational motion acts perpendicular to the equipment axis of rotation, such as a combination of the vectors from X and Y axes (this value amounted to +7 Gz in this study). Therefore, the resulting body acceleration occurs along the longitudinal direction of the container, inducing accelerated growth (this is the resultant acceleration that allows the simulation of induced hypergravity).

Using small-scale centrifuges similar to the one described here, previous investigations discovered that hypergravity stimulates at a cellular level both the lignin formation and the peroxidase enzyme action in Japanese beans (*Vigna angularis*). Consequently, this stimulus creates a reinforced cellular wall due to the adaptive response to the hypergravity [7,8]. When applied to rice seeds, it was possible to observe that hypergravity exposure led to the formation of both bigger and thicker

roots. In all cases, hypergravity has been prejudicial to chlorophyll formation [9].

Another study using *Raphanus sativus* L., demonstrated a total length reduction, but revealed increased thickness of both the roots and the above ground shoots, as well as a greater production of cellular wall compounds [10]. Yet further research involving the centrifugation of seeds up to 300 Gz, investigated how certain genes manifest under hypergravity [11].

Studies performed with *Eruca Sativa Mill* have verified that seeds stimulated by +7Gz germinated after two days, whereas the control sample required four or more days. In addition, the centrifuged seeds had an average root growth of 3.2 cm, in contrast to 1.9 cm for the control samples [12]. However, due to their nutritional properties, the leaves of this vegetable are the part with the most commercial value as they contain not only iron and vitamins A and C, but also essential oils. These oils could be used in the chemical industry and in medicines [13].

In order to broaden the investigations for this scientific branch, this research group developed a new piece of equipment, enhanced in mechanical performance and featured with an inbuilt instrumentation system for electronic monitoring via sensors and video camera. This paper presents the conception, development and validation of this mechanical-high-performance centrifuge, together with an integrated electro-electronic system, enabling greater control over the assessment of the variables.

The paper is structured as follows: Section II presents a background detailing the first centrifuge version; Section III highlights the new equipment, describing the mechanical, electro-mechanical and electronic system; Section IV presents the methodology adopted for validation procedures; Section V and VI present the results and conclusion, respectively.

## 1.1. Background

The Joan Vernikos Aerospace Pharmacy Laboratory at the Microgravity Centre, PUCRS, has been investigating the effects of hypergravity simulations since 2005, when the construction of the first centrifuge for plant research took place. The device enabled important studies be accomplished and, as a result, a patent application entitled "Process of growing plants under hypergravity conditions" was filed in Brazil (PI 0705245-6), Europe (EP08772762.4) and has already been granted in US (US8443544) [16].

The centrifuge, based on an earlier prototype for educational proposes [14,15], was composed of three circular PVC trays of 560 mm in diameter, affixed on top of each other, and a DC electric motor. Each tray was capable of holding up to 12 samples at once in semi-circular recesses, secured by polyester bearings. Two stainless steel pins (3 mm diameter and 13 mm length), present in each bearing, were responsible for supporting the sample containers in place without restricting their angular movement, thus enabling the alignment of the sample with the spin's resultant vector. The bearings had sufficient mechanical strength to endure the weight load produced by the sample mass during hypergravity simulation, while a 20 mm flange, perpendicular to the base of the tray, prevented them from escaping the semi-circular recesses.

Figure 2 presents the general features of the original centrifuge version of the Microgravity Centre.



Figure 2. The original centrifuge used as a reference for building the new version.

However, due to limitations in its design and assembly, the centrifuge presented a lack of stability, causing it to oscillate during rotation. This undesired movement became more evident in the structure the further away it was from the motor. As a consequence, results given by samples placed on the upper trays were not as reliable as those from the lower tray, thus inhibiting the overall consistency of experiments.

Aiming to overcome these limitations and, thus, to provide an improved device for future research, a new centrifuge was designed. Additionally, an instrumentation system project was incorporated to the design to allow environmental conditions to be monitored and sample development to be recorded.

## 2. Materials and Methods

This paper demonstrates the design and construction of this improved centrifuge, which is composed of three main systems: mechanical; electro-mechanical and electronic instrumentation. Details of these three main components follow, in relation to their concept, the manufacturing process and their functionality in the system as a whole.

The exploded view of the mechanical system of the centrifuge is presented in Figure 3, and each component is explained in details throughout the text.

### 2.1. The Mechanical System

The centrifuge's mechanical system consists of three main and several complementary parts, as depicted in Figure 3 and described in the following paragraphs.

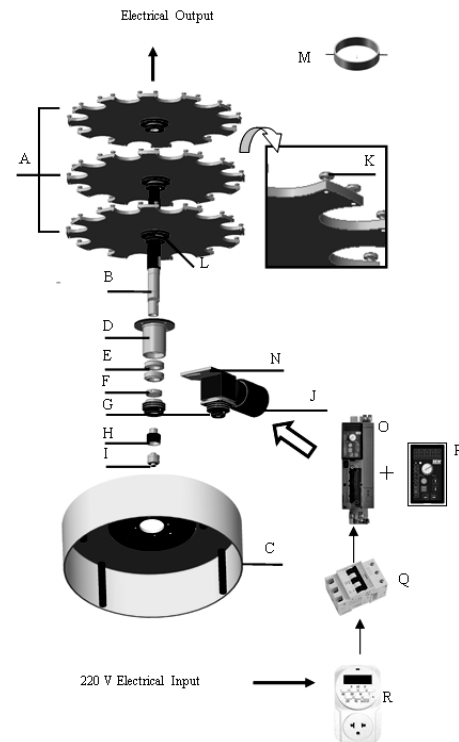

Figure 3. The exploded view of the mechanical system

#### 2.1.1. Circular Trays (Figure 3 - item A)

Oxyacetylene gas was used to cut the 660 mm diameter circular trays from PVC sheets with dimensions of 2440 mm x 1220 mm x 10 mm. Each tray has a centralized hole of 50 mm, which enables it to be placed on the central axis. Twelve semi-circular recesses of 106 mm diameter were created along the outer border of the tray to accommodate the sample holders during the experiments.

#### 2.1.2. Central Axis (Figure 3 - item B)

The central axis was manufactured from a 1045 steel tube, having a 50 mm outer diameter and a central circular opening of 25 mm diameter. This inner space is used for passing the electrical wiring between the components and the power supply. The tube was slightly indented at three different heights to accommodate the fixture of the Circular Trays.

#### 2.1.3. Base (Figure 3 - item C)

The Base is a closed cylinder to provide protection for the components of the secondary mechanical structure held within. The Base is designed to be heavy enough to securely maintain the complete structure in place while the centrifuge is operating. The centre of gravity is low as the principal weight is concentrated at the base, which guarantees a stable rotation of the Central Axis. Its construction was based on a 620 mm diameter 1020 steel tube with 3.175 mm walls. The original tube was horizontally cut with oxyacetylene gas at a height of 250 mm, and a circular lid welded in place formed from the same material and with the same diameter as the tube. The lid included a centralized hole of 80 mm diameter. The Base rests on four feet composed of circular screws coated with a shock-absorbing rubber material. These are fixed in a manner that a 10 mm gap remaining at the bottom of the tube guarantees the natural cooling of the internal components.

Various complementary pieces for support, fixation, bearing and force transmission have been projected and implemented into the centrifuge. The majority of these pieces are situated inside the cylindrical base and are detailed as follows:

- Bearing Drum (D);
- Ball-Bearings (E);
- Oil Retainer (F);
- Two Pulleys Connected by a Transmission Belt (G);
- Rotation Connector Support (H);
- Rotation Connector (I);
- Motor Reduction Unit (J);
- Support Dowels (K);
- Tray Mounting Flanges to the Central Axis (L);
- Sample Holder Support (M);
- Belt Regulation System (N);
- Inverter Frequency Converter (O);
- Control Panel (P);
- Tripolar Disconnecter (Q);
- Digital Power Timer (R).

## 2.2. The Electro-mechanical System

The electro-mechanical system consists of five distinct components shown in Figure 3 and detailed below. This system is responsible for the generation and transmission of torque and energy. In addition, there are some integrated components that allow the scheduling of working periods and configuration of mechanical parameters.

### 2.2.1. Motor Reduction Unit (Figure 3 - item J)

The motor reduction unit is attached to the central axis of the centrifuge and controlled by the frequency converter. It has a power of 0.1 Kw giving rotations of up to 200 rpm and a torque of 4 N.m and resulting in a maximum centrifugal acceleration of 15 G. As the unit is connected to the central axis, its rotation is responsible for the movement that creates the hypergravity necessary for the experiment.

### 2.2.2. Frequency Converter (Figure 3 - item O)

The frequency converter automatically controls the rotation speed of the connected motor reduction unit. The MOVITRAC converter works with a power of 0.25 kW.

### 2.2.3. Control Panel (Figure 3 - item P)

The control panel enables the user to program and store the frequency converter internal configuration parameters and, therefore, control the rotation characteristics of the gear motor reduction unit. Maximum rotation speed, engine acceleration and deceleration ramps and maximum power consumption are some of these possible settings. The panel also has a manual operation feature allowing control of the rotation speed by means of a turning knob on the panel.

### 2.2.4. Tripolar Disconnecter (Figure 3 - item Q)

The tripolar disconnecter is a three-pole breaker, responsible for electrical protection in the event of a short circuit.

### 2.2.5. Digital Timer Bivolt (Figure - item R)

A Digital Timer Bivolt was coupled to the grid connection in order to enable programming of the system, cutting and automatically activating the electrical energy in accordance with the schedules established by research protocols.

## 2.3. The Electronic System

The Electronic System is comprised of three groups of components fixed to the top of the upper Circular Tray and the External Power Supply. These components monitor and transmit the information related to the experiment. The organization of the single components and sub-systems is described in more detail below.

### 2.3.1. VHF Capturing and Transmission Unit

The VHF Capturing Unit is made up of two different modules. The first module is responsible for capturing the image from the control sample holder, which is not placed inside the centrifuge. In the sequence, the images are digitalized and sent to a USB port in the Processing Unit. The images received are saved on an external hard disk with a 500 GB capacity. Figure 4 presents a block diagram of this process.

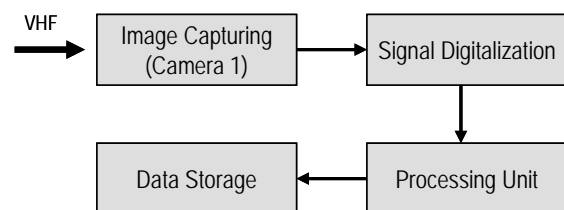

Figure 4. Block diagram presenting the VHF capturing process for the first module.

The second module consists of a miniature colour camera fixed to the upper circular tray to monitor a holder containing sample plants. It is important to highlight that the camera is fixed in place using a flexible aluminium support, which enables it to follow the movement produced by the centrifugal acceleration with adjustments along the transversal axis. In this way, the camera is kept at a constant distance of 40 mm from the holder. Figure 5 shows the miniature camera as attached to this support.

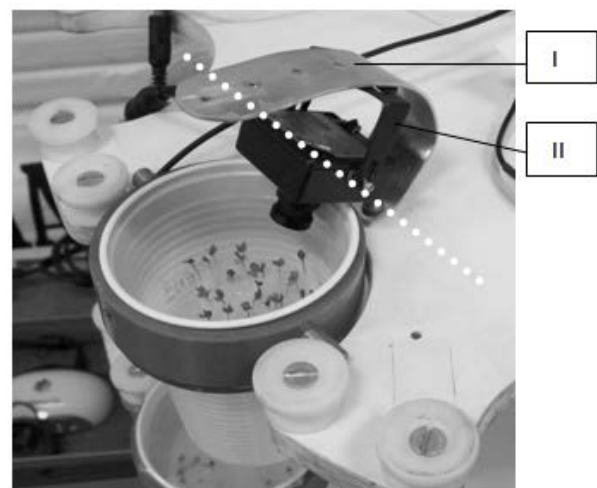

Figure 5. The image capturing system. In the figure above: (I) Flexible aluminium support; (II) Rigid support, the dotted line indicates the axis of free rotation allowed for the miniature camera.



The transmission unit is fixed to the upper Circular Tray. The images are transmitted in analogical form using a multidirectional antenna with a transmission radius of approximately 50 m. The transmitted images are captured by an analogical antenna, which is connected to a video recorder. This recorder sends the signal via cable to a portable external video-capturing card connected to the USB port of the Processing Unit. The visualization software provides the option of selecting the capturing source and video format, as well as allowing a programmed recording schedule to be made. The received images are saved on an external hard disk with a 1TB data storage capacity. Figure 6 demonstrates a block diagram of this process.

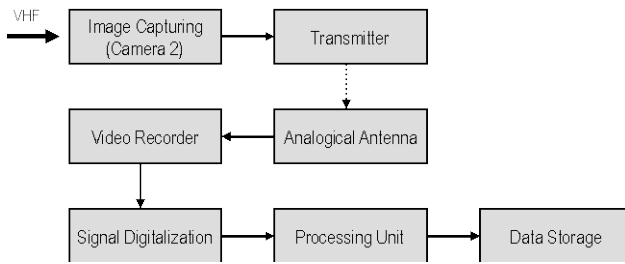

Figure 6. Block diagram presenting both the VHF capturing and transmission for the second module.

2.3.2. Acceleration Sensor

A bi-axial accelerometer was used to measure the centrifuge acceleration, with the data being transmitted via an RF transmission card and Xbee transmission module, sending the measured analogical voltage. It is important to note that an operational amplifier was used to reduce the sensor output voltage, whilst causing no data loss. In this manner, it is possible to avoid any damage to the Xbee that may be caused by its having a lower supply voltage. A card, including an Xbee reception module, was developed to digitalize the received analogical signals before sending them to the Processing Unit. The data is then transformed by software written in C#, into the required physical units. Figure 7 presents a block diagram of this process.

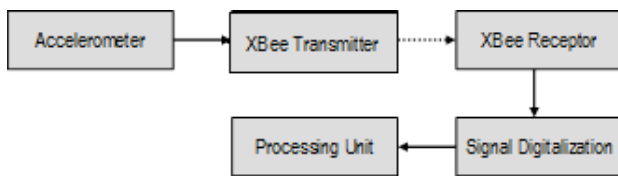

Figure 7. Block diagram representing the data acquisition and transmission from the accelerometer to the Processing Unit.

2.3.3. Temperature and Humidity Sensor

A Relative Humidity and Temperature (RHT) sensor is used to measure the environment temperature and humidity. The collected data is transmitted via an RF transmission card and Xbee transmission module that sends the measured analogical voltage. Again, it is important to note that an operational amplifier reduced the sensor output voltage, without the loss of data, in order to avoid damage to the Xbee that may be caused by its lower supply voltage. A card, including an Xbee reception module, was developed to digitalize the received analogical signals before sending them to the Processing

Unit. The data is then transformed by software written in C#, into the required physical units. Figure 8 depicts the block diagram of this process.

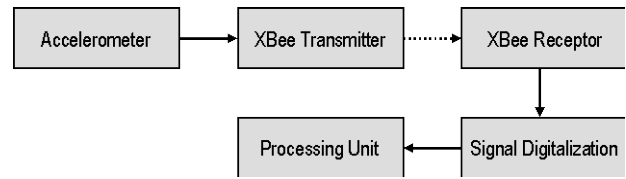

Figure 8. Block diagram presenting the data acquisition and transmission from the RHT sensor to the Processing Unit.

2.3.4. External Power Supply

All components fixed on the upper Circular Tray are connected to a 24V power supply situated externally alongside the moving parts. A rotary connector is used to make the connection between the supply and the components. Figure 9 shows the block diagram for the power supply.

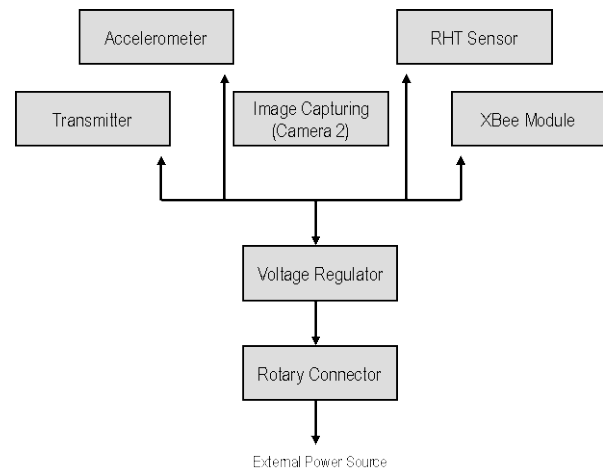

Figure 9. Block diagram showing all components powered by the External Power Source. The rotary connector promotes the electrical signal transmission from the static to dynamic system.

3. Validation Protocol

A validation protocol was defined in order to certify the new centrifuge as a scientifically viable piece of equipment. The basis of this protocol was to compare in parallel the growth of vegetable samples using the new centrifuge with results obtained using the original version presented in [1], as well as making a comparison with the control samples. All experiments have been performed using *Eruca sativa Mill* seeds. The control samples were subject to earth’s gravity (1G) for 96 hours, while the samples from the two centrifuges were submitted to 4 cycles of 8 hours applying a stimulus of +7Gz, separated by intervals of 16 hours at rest.

The total experimental time was 4 days at a constant environment temperature of 22°C. Analysis involved the measurement of the plant roots and the above ground shoots using a universal mechanical calliper. Table 1 presents the division of the groups and their respective validation protocols. Table II presents the results in terms of the arithmetic mean and standard deviation so that a comparison can be made between the plant growth measurements from the three different groups.

**Table 1. Methodology to validate the centrifuge V2**

Group	Validation Protocol
Control	Growing during 96 h at +1Gz
Centrifuge V1	4 series of 8 h of stimulus at +7Gz, using intervals of 16 h at +1Gz
Centrifuge V2	4 series of 8 h of stimulus at +7Gz, using intervals of 16 h at +1Gz

Three experiments were performed under the same conditions. The mean plant growth between Centrifuges V1 and Centrifuge V2 was expected to be similar, with both these results expected to be superior to those of the Control group.

In addition, the stability of the central axis was verified by means of tachometer measurements with photo and digital contact, which were placed at four different levels along the central axis (Figure 10). Three trials of 8 continuous hours were conducted, with measurements being made at four different time intervals. The first trial was performed at 20 rpm, which is considered to be low speed. The second trial ran at 134 rpm, this being the speed at which the plant growth experiments would run, and finally, the third trial was performed at 200 rpm, representing the maximum speed of the centrifuge.

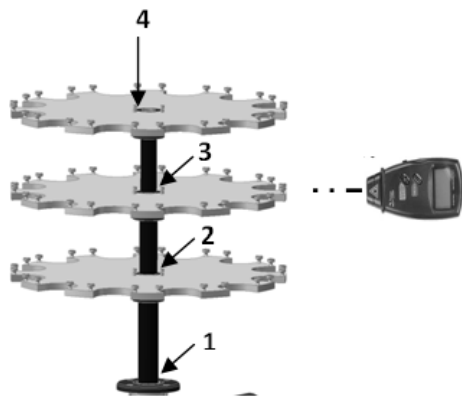

**Figure 10.** RPM readings. Arrows indicate points where central axis measurements were taken (numbers 1 to 4). To the right of the figure is the tachometer photo and contact used. Optical measurements were performed at points 1 to 3 by means of reflected laser reflective tape attached to shaft surface. Measurement was obtained via the contact technique at point 4, due to its location.

## 4. Results

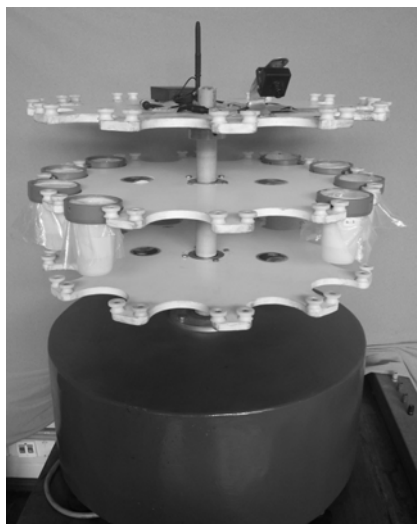

**Figure 11.** Picture of Centrifuge V2 and integrated systems

The results obtained from the experiments performed according to the validation protocol are herein summarized. Figure 11 presents the modified centrifuge proposed in this paper.

Table 2 summarizes the statistical analysis of all collected data obtained during the experiments.

**Table 2. Mean ( $\pm$ SD) of the three groups, containing the V1 (N=18), V2 (N=18) and control group (N=18)**

Group	Roots [mm]	Shoots [mm]	Total Length [mm]	Germinated Seeds
Control	3.31 $\pm$ 1.54	1.64 $\pm$ 1.03	4.92 $\pm$ 2.57	11.26 $\pm$ 2.53
Centrifuge V1	5.07 $\pm$ 1.32	2.18 $\pm$ 0.88	7.25 $\pm$ 2.23	13.94 $\pm$ 3.09
Centrifuge V2	5.01 $\pm$ 2.06	2.10 $\pm$ 1.12	7.11 $\pm$ 3.18	13.61 $\pm$ 3.55

The difference between mean growth figures for the plant shoots for the two centrifuges was not significant, when considering the ANOVA test ( $p > 0.05$ ). However, when comparing the centrifuge results to those of the control group, the values show a significant difference ( $p < 0.05$ ).

The same result holds true for the analysis of roots and total length of the seedlings. It was also observed that a larger number of seeds germinated from those samples that received hypergravity stimulation. Table 3 summarizes the RPM measurements.

**Table 3. Mean ( $\pm$ SD) of the three trials at different speeds along the central axis (N=18)**

Experiment	Point 1	Point 2	Point 3	Point 4
1 (20rpm)	20.11 $\pm$ 0.32	20.91 $\pm$ 0.88	21.03 $\pm$ 1.23	21.43 $\pm$ 1.72
2 (134rpm)	133.42 $\pm$ 0.1	135.9 $\pm$ 1.12	135.2 $\pm$ 1.18	136.61 $\pm$ 2.0
3 (200rpm)	200.35 $\pm$ 1.5	202.71 $\pm$ 1.0	205.01 $\pm$ 2.5	205.29 $\pm$ 4.5
	4	3	7	3

The variation analysis demonstrates the stability of the central axis of the centrifuge, with the overall variation not being significant. As expected, however, the points closer to the base had values nearer the desired speed for the three tests. The further the point from the base, the more likely that the mean value will show a greater alteration in relation to the desired value. However, this variation is not significant.

Overall, the modified centrifuge V2 worked well, giving a good mechanical and electromechanical performance. The structure remained stable during the entire test procedure, providing a homogeneous distribution of the applied centrifugal force to all samples. Systems and components behaved in accordance with the requirements and met the constructive objectives.

The creation of a closed base ensured greater protection for the electromechanical components and the three layers of trays enabled 36 sample holders to be satisfactorily rotated simultaneously. The system of power generation and transmission was compatible with the generated power, making it possible to produce a G Force of +15 Gz.

The mean root growth of the plants tested in Centrifuge V2 was very similar to those produced with Centrifuge V1, and also compared well with the results presented in [1], proving the reproducibility of the scientific process and the importance of the modified centrifuge V2 as an established scientific tool.

## 5. Conclusions

This paper presented a new centrifuge and detailed its integrated system for the monitoring of samples. The validation of the equipment has demonstrated that the new centrifuge is a viable and reliable tool for scientific application [1]. The samples grown under hypergravity stimulation using the new centrifuge were statistically similar when compared to those grown under stimulation with the original centrifuge version.

The results regarding the centrifuge performance and the case studies conducted helped to show the viability of the machine as an efficient tool for scientific purposes, demonstrating the integrity and importance of generating further research in hypergravity. Both the structure and the system have proven to be promising in regards to its applicability to aerospace research, since it is possible to study plant physiology for applicability to future plant growth in space. The use of protocols of exposure to hypergravity may be a very enlightening feature, enabling the generation of different stimuli, and in addition, being linked to techniques for monitoring the environment and the generation of images. These features translate into future research in the field of hypergravity, with the prospect of giving results comparable to those employed in investigations conducted by major space agencies around the world.

## References

- [1] Russomano, T; Rizzatti, M; Coelho, RP et al. "Effects of simulated hypergravity on biomedical experiments". IEEE Engineering in Medicine and Biology Magazine. Marh/April, 2007.
- [2] Smith, J. "Plant growth and imaging in a hypergravity environment". 2011. IEEE Engineering in Medicine and Biology Magazine. Sept/Oct, 2009.
- [3] Michele, SG. "Desenvolvimento de uma gôndola para realização de experimentos em uma centrífuga". Master of Science Thesis. PUCRS. Porto Alegre, 2007.
- [4] Karp, G. "Cell and molecular biology: Concepts and experiments", 4<sup>a</sup> ed., Editora Von Hoffman, 2005.
- [5] NASA Ames Research Center. "Research and Technology Report 2010". Doc TM 110419, 262 p., 2010.
- [6] Cowing, K. "NASA hack space project". Gravitational Biology Magazine. Vol 32, 2004.
- [7] Wakabayashi, K; Nakano, S; Soga, K. "Cell wall-bound peroxidase activity and lignin formation in azuki bean epicotyls grown under hypergravity conditions". Journal of Plant Physiology. Vol 166, p. 947-954, 2009
- [8] Chen, N; Siegel, SM; and Siegel, B L. "Gravity and Land Plant Evolution: Experimental Induction of Lignification by Simulated Hypergravity and Water Stress". Life Sciences and Space Research, vol. 18, p. 193-198, 1980.
- [9] Vidyasagar, P; Jagtap, S; Nirhali, A; et al. "Effects of hypergravity on the chlorophyll content and growth of root and shoot during development in rice plants". Biomedical and Life Sciences. Vol. 24, p. 1599-1602, 2008.
- [10] Kasahara, H; Shiwa, M; Takeuchi, Y; et al. "Effects of hypergravity on the elongation growth in radish and cucumber hypocotyls". Journal of Plant Research. Vol. 108, p. 59-64, 1995.
- [11] Tamaoki, D; Karahara, T; Nishiuchi, S; et al. "Transcriptome profiling in Arabidopsis inflorescence stems grown under hypergravity in term of cells walls and plant hormones". Advances in Space Research. Vol. 44, p. 245-253, 2009.
- [12] Russomano, T; Rissati, MR; Coelho, RP; Scolari, D; Souza, D.; Práveleda, P. "Effects of Simulated Hypergravity on Biomedical Experiments". IEE Engineering in Medicine and Biology Magazine, May-June, 2007
- [13] Karp, G. Cell and molecular biology: Concepts and experiments, 4<sup>a</sup> ed., Editora Von Hoffman, 2005.
- [14] Azevedo, DFG; Russomano, T. Coelho, RP; et al. "Development of educational tools to demonstrate the effects of hyper and microgravity on different test bodies". 26<sup>th</sup> Annual International Conference, IEEE, 2004.
- [15] Coelho, RP. Desenvolvimento de centrífugas para experimentos em hipergravidade. PUCRS, Porto Alegre, 2005.
- [16] Russomano, T; Falcão, FP; Marlise, AS; et al. "Process of growing plants under hypergravity conditions". US Patent n. 2010/0180499 A1. Jul 22, 2010.